

20B	REPAANEL TO SAME AS 220-02024-19	TB	SH	ML	SH	19JUL05
20A	ECO IC702 ADDED	CJK	SH	CJK	SH	03JUN05
REV/ISS	AMENDMENTS	DRAWN	CHKD	D.O.	APVD	DATE
1		3		4		5

© TAIT ELECTRONICS A1

TB8100
RECITER CONTROL

IPN: 220-02024-20 ISSUE: B VARIANT NUMBER: ?

ENGINEER: SH FILE NAME: 220_02024 SHEET NUMBER: 1 OF 18

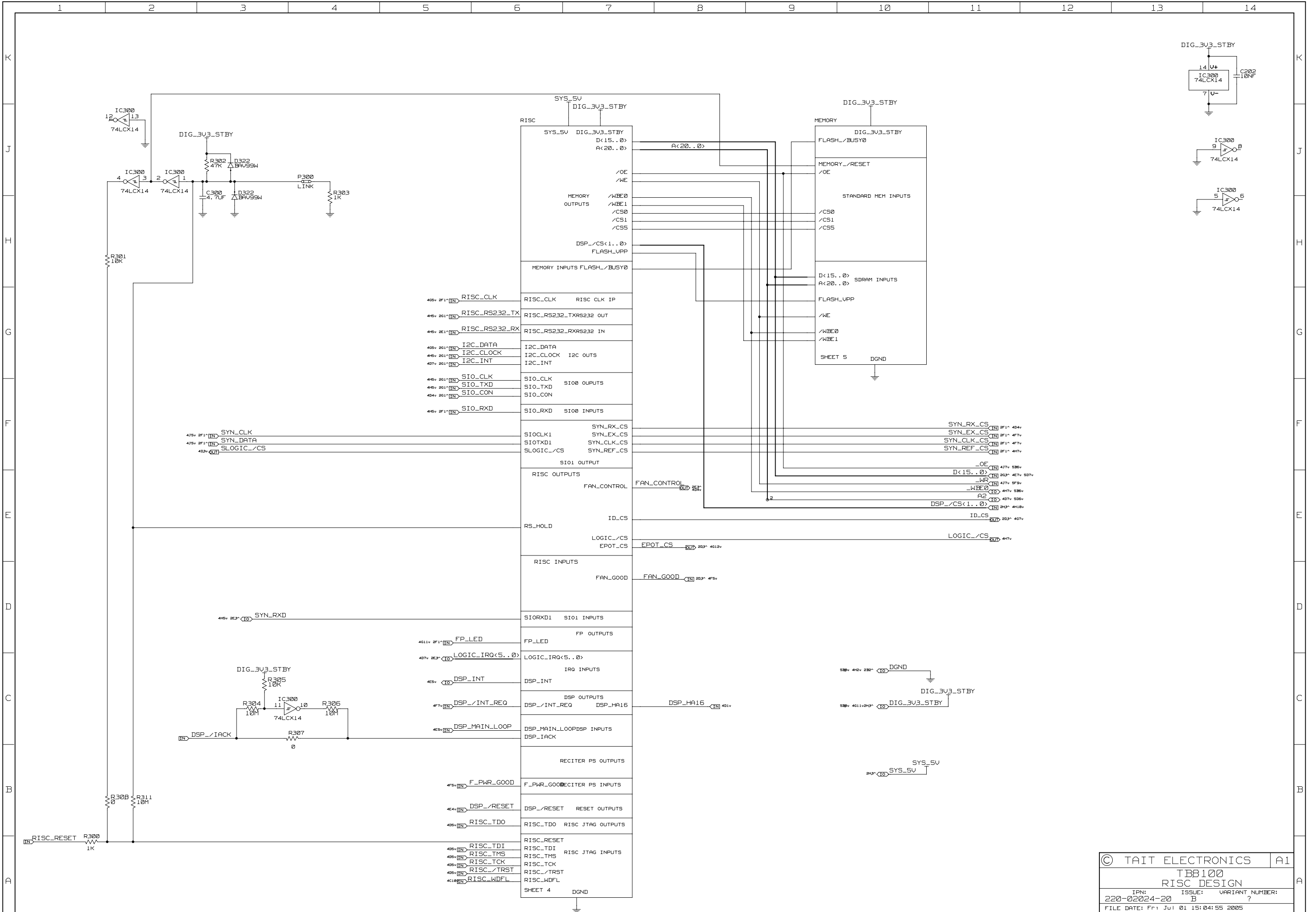

© TAIT ELECTRONICS		A1
TB8100 RISC DESIGN		
IPN: 220-02024-20	ISSUE: B	VARIANT NUMBER: ?
FILE DATE: Fri Jul 01 15:04:55 2005		
ENGINEER: SH	FILE NAME: 220_02024	SHEET NUMBER: 3 OF 18

REV/ISS	AMENDMENTS	DRAWN	CHKD	D.O.	APVD	DATE
1						

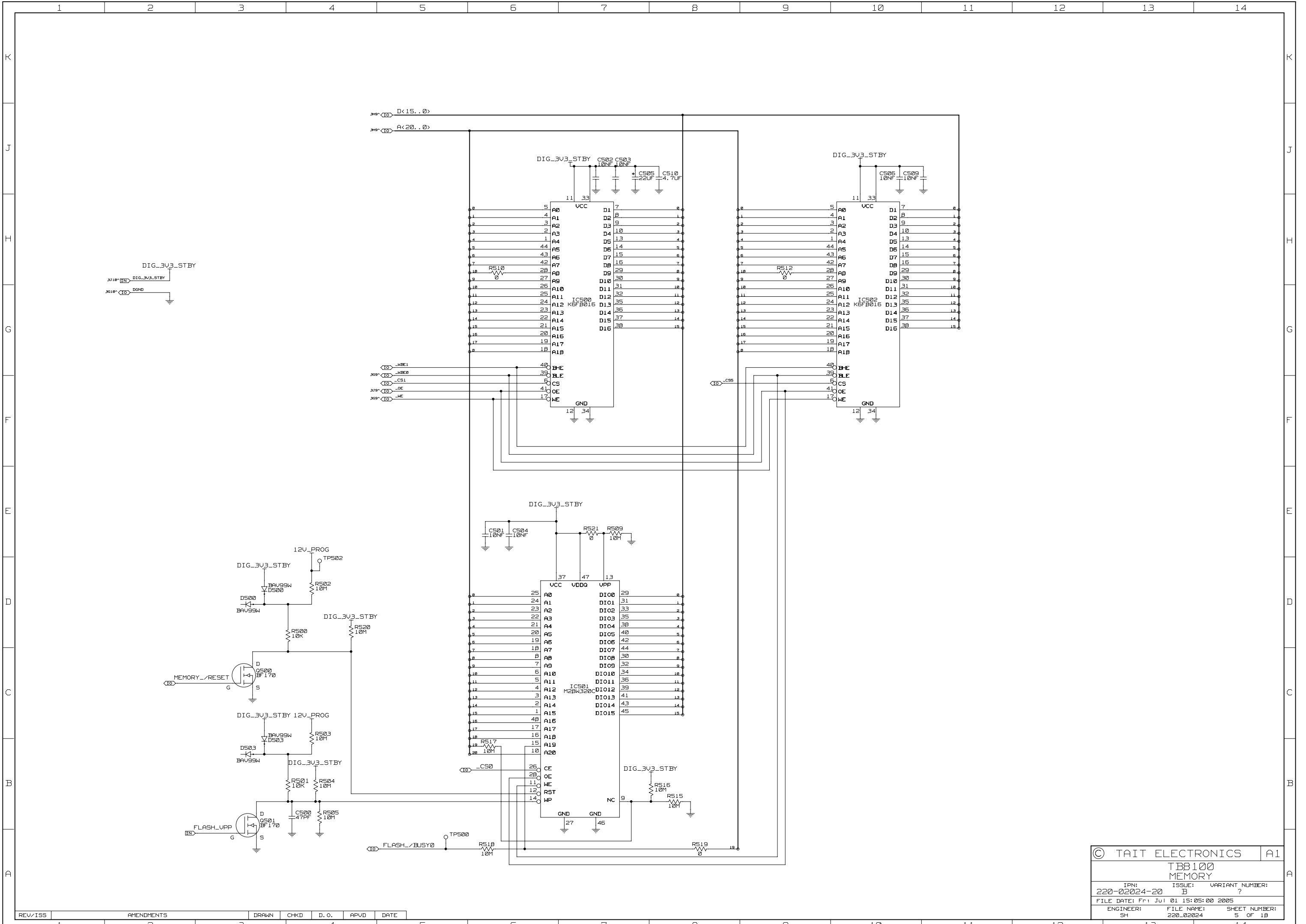

© TAIT ELECTRONICS		A1
TB8100 MEMORY		
IPN: 220-02024-20	ISSUE: B	VARIANT NUMBER: ?
FILE DATE: Fri Jul 01 15:05:00 2005		
ENGINEER: SH	FILE NAME: 220_02024	SHEET NUMBER: 5 OF 18

REV/ISS	AMENDMENTS	DRAWN	CHKD	D.O.	APVD	DATE
1						

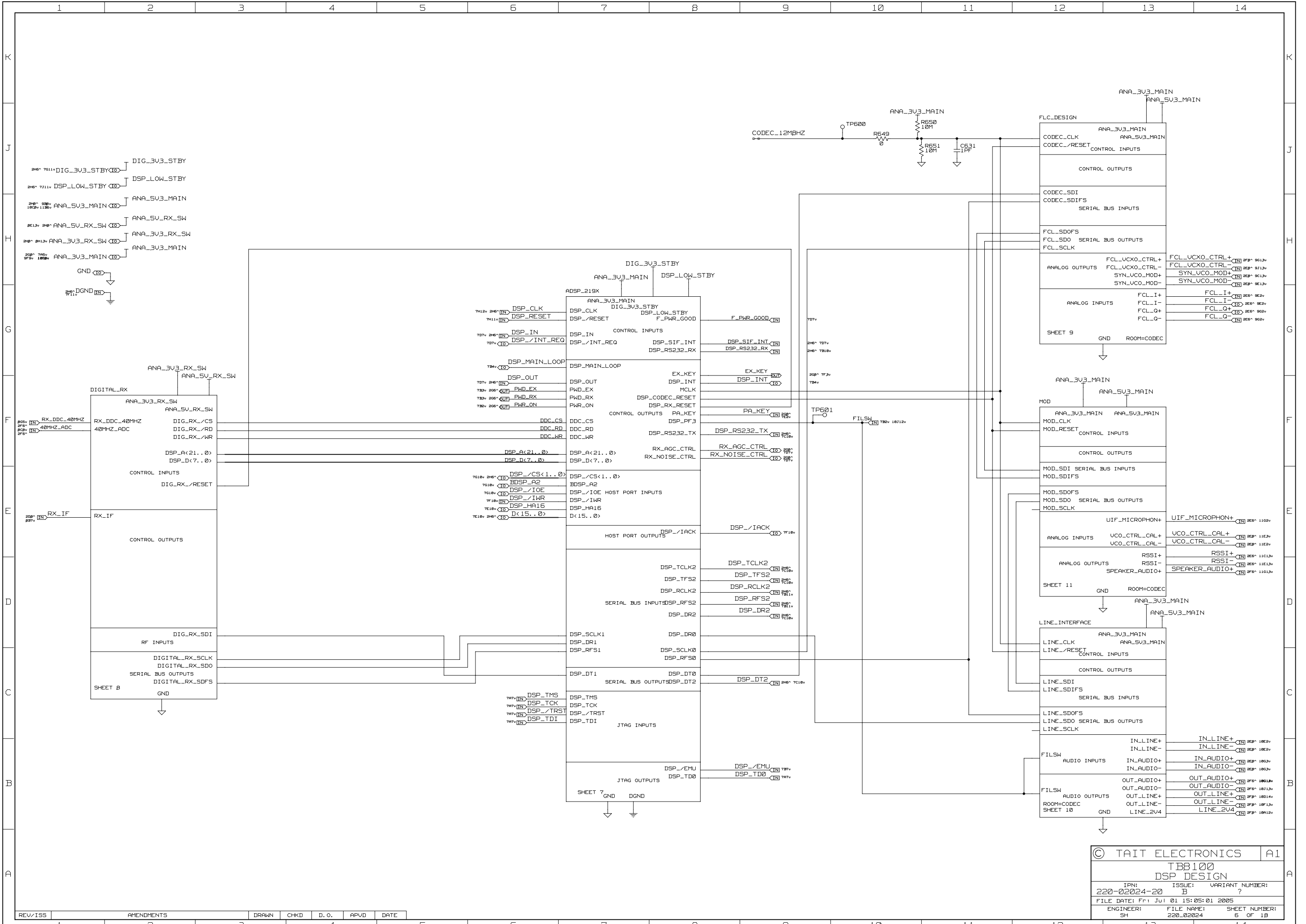

© TAIT ELECTRONICS | A1

TB8100
DSP DESIGN

IPN: 220-02024-20 | ISSUE: B | VARIANT NUMBER: ?

FILE DATE: Fri Jul 01 15:05:01 2005

ENGINEER: SH | FILE NAME: 220_02024 | SHEET NUMBER: 6 OF 18

REV/ISS	AMENDMENTS	DRAWN	CHKD	D.O.	APVD	DATE
1						

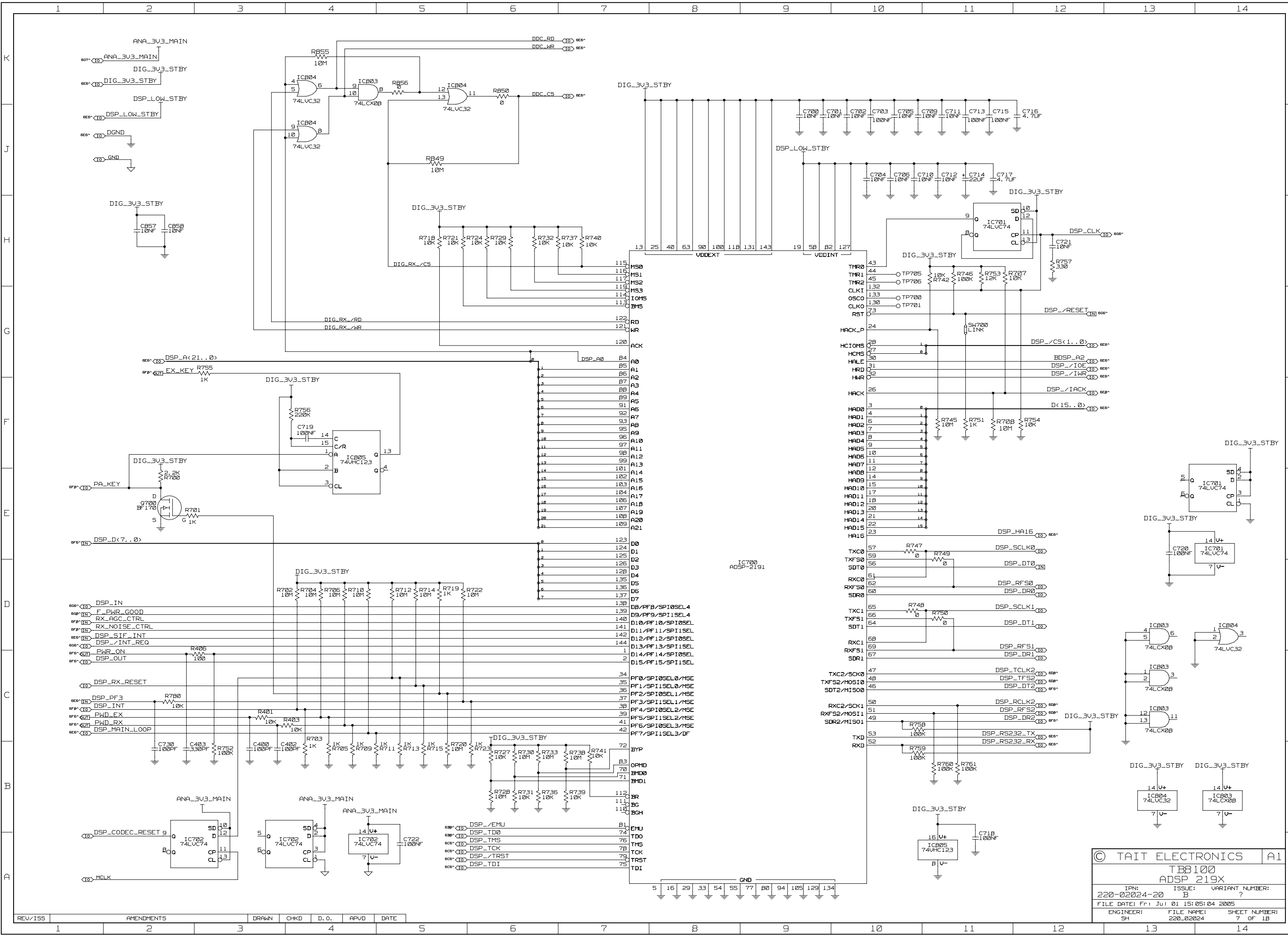

© TAIT ELECTRONICS		A1
TBB100 ADSP 219X		
IPN: 220-02024-20	ISSUE: B	VARIANT NUMBER: ?
FILE DATE: Fri Jul 01 15:05:04 2005	FILE NAME: 220_02024	SHEET NUMBER: 7 OF 18
ENGINEER: SH		

REV/ISS	AMENDMENTS	DRAWN	CHKD	D.O.	APUD	DATE
1						

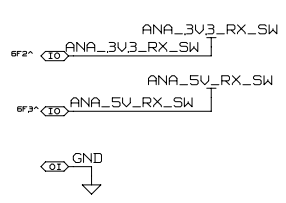
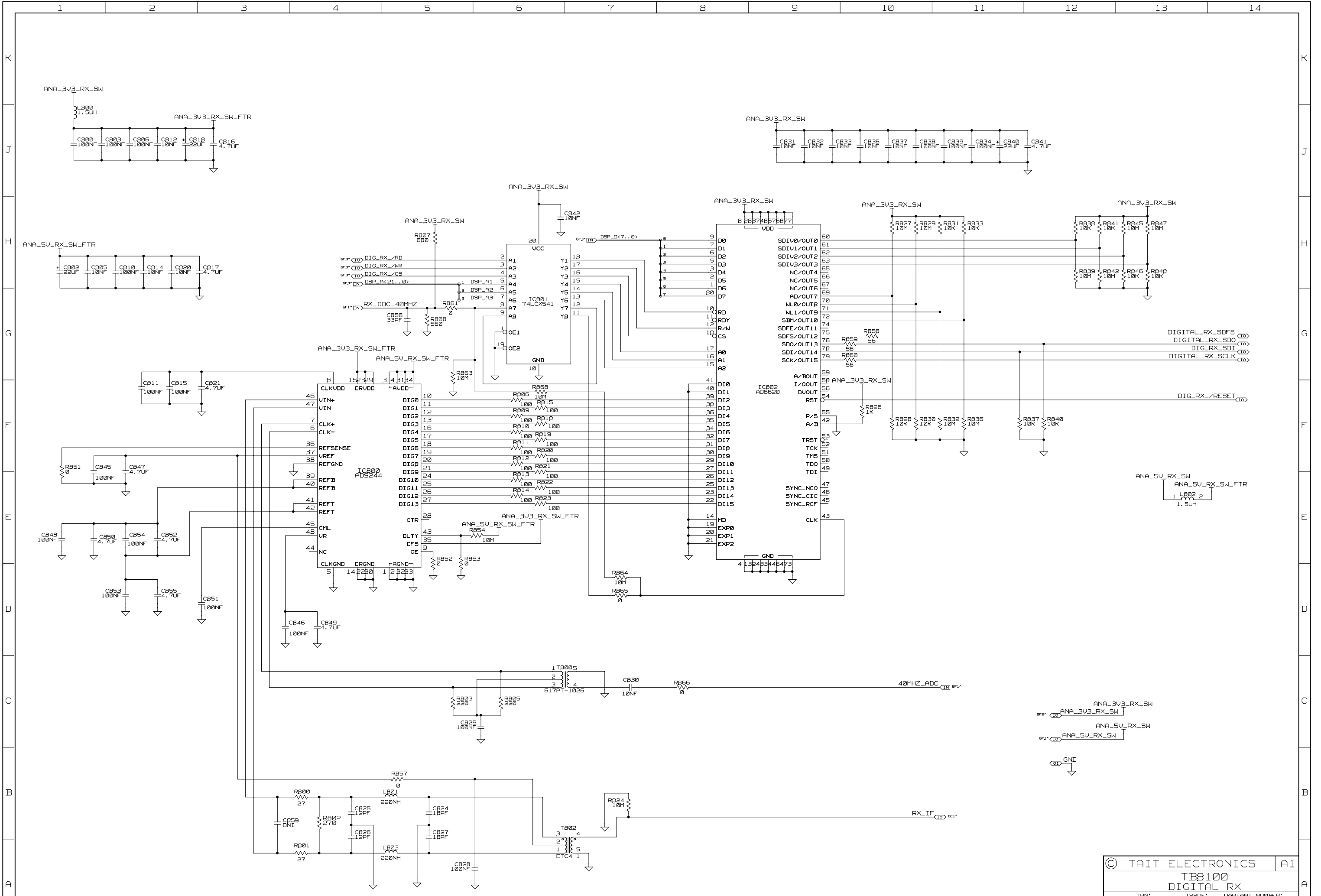

© TAIT ELECTRONICS		A1
TB8100 DIGITAL RX		
IPN: 220-02024-20	ISSUE: B	VARIANT NUMBER: ?
FILE DATE: Fri Jul 01 15:05:05 2005		
ENGINEER: SH	FILE NAME: 220_02024	SHEET NUMBER: B OF 1B

REV/ISS	AMENDMENTS	DRAWN	CHKD	D.O.	APVD	DATE
1						

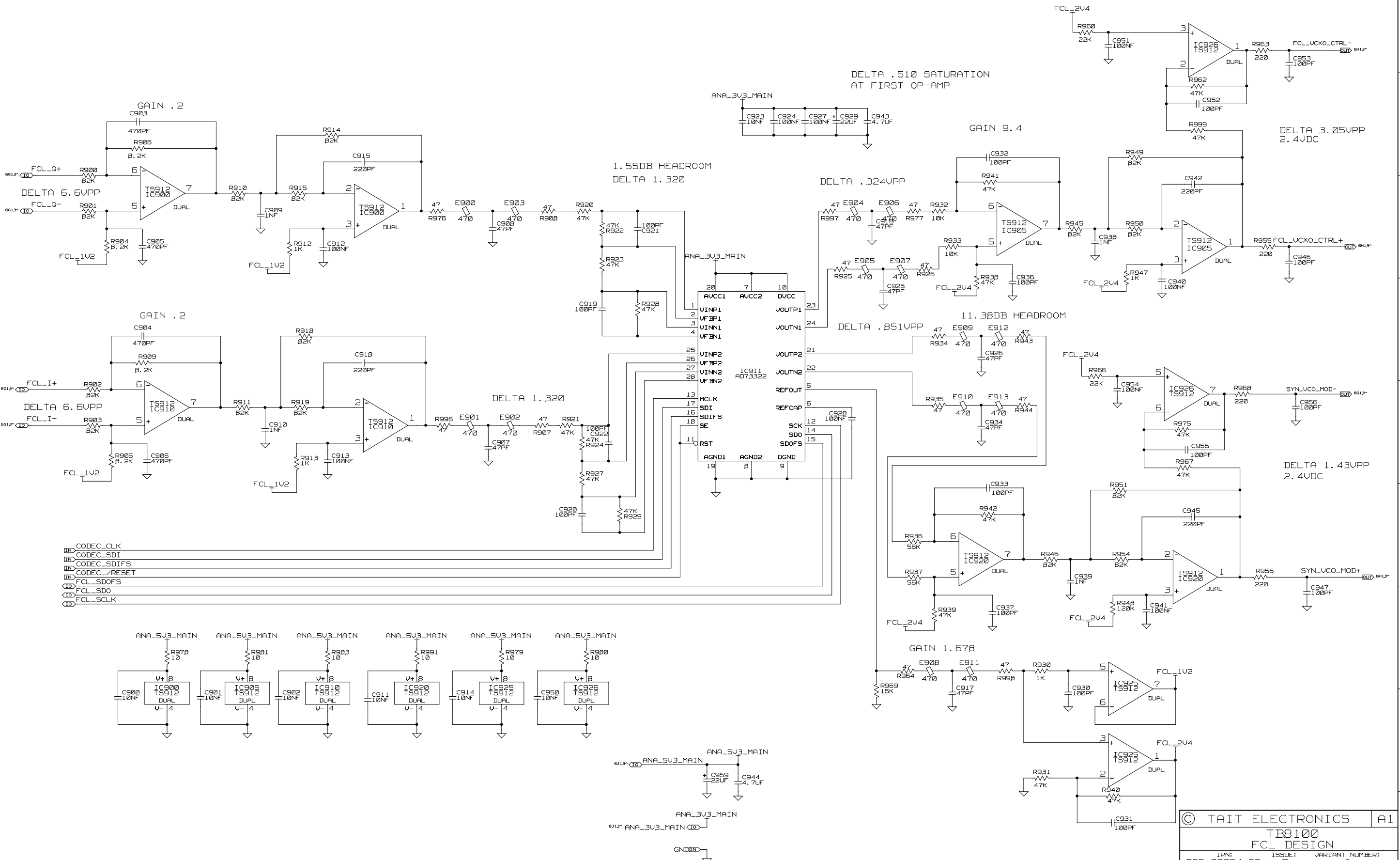

© TAIT ELECTRONICS		A1
TB8100		
FCL DESIGN		
IPN:	ISSUE:	VARIANT NUMBER:
220-02024-20	B	?
FILE DATE: Fri Jul 01 15:05:09 2005		
ENGINEER:	FILE NAME:	SHEET NUMBER:
SH	220_02024	9 OF 18

REV/ISS	AMENDMENTS	DRAWN	CHKD	D.O.	APVD	DATE
1						

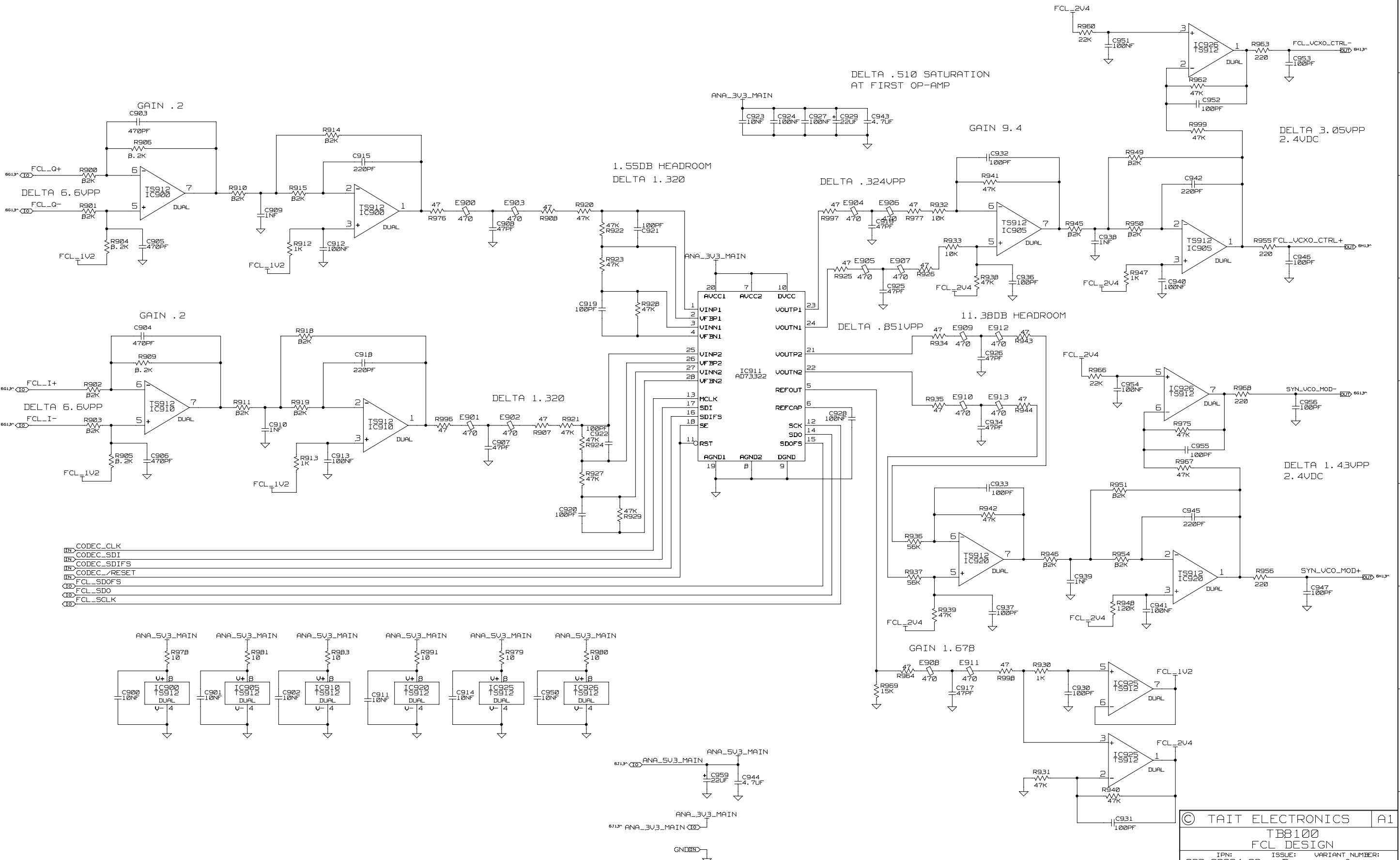

© TAIT ELECTRONICS		A1
TB100 FCL DESIGN		
IPN: 220-02024-20	ISSUE: B	VARIANT NUMBER: ?
FILE DATE: Fri Jul 01 15:05:09 2005		
ENGINEER: SH	FILE NAME: 220_02024	SHEET NUMBER: 9 OF 18

REV/ISS	AMENDMENTS	DRAWN	CHKD	D.O.	APVD	DATE
1						

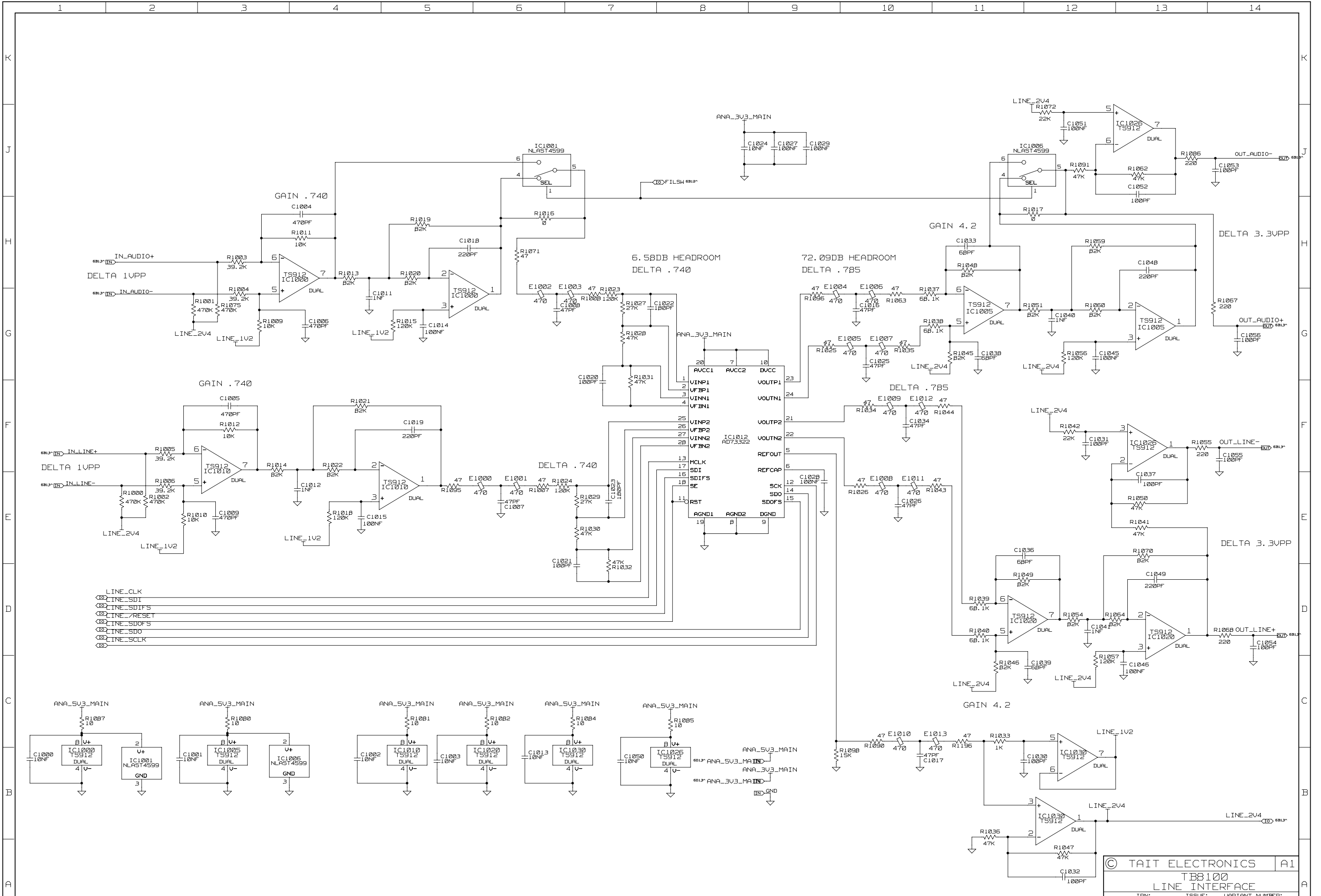

© TAIT ELECTRONICS		A1
TB8100		
LINE INTERFACE		
IPN:	ISSUE:	VARIANT NUMBER:
220-02024-20	B	?
FILE DATE: Fri Jul 01 15:05:12 2005		
ENGINEER:	FILE NAME:	SHEET NUMBER:
SH	220_02024	10 OF 18

REV/ISS	AMENDMENTS	DRAWN	CHKD	D.O.	APVD	DATE
1						

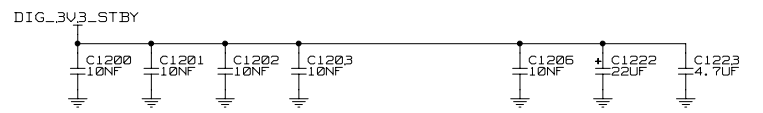
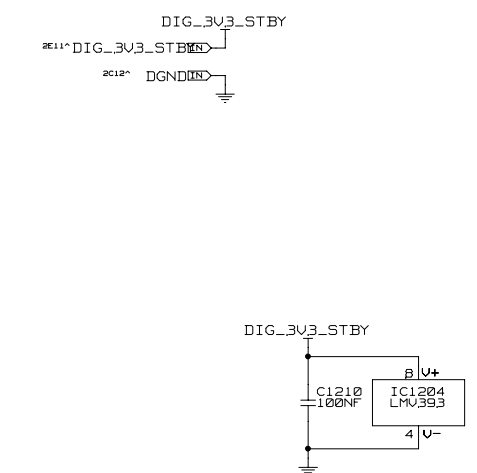
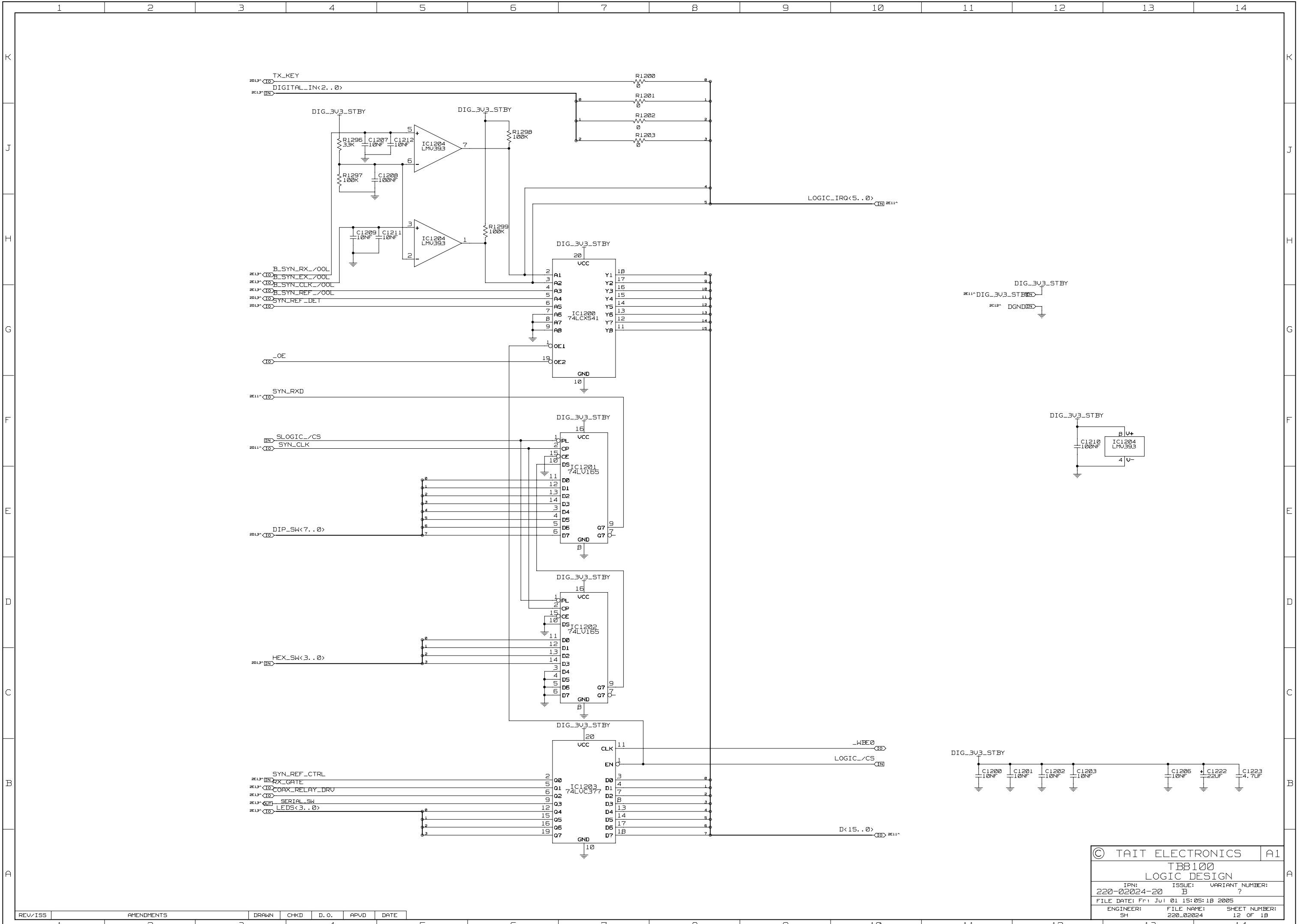

© TAIT ELECTRONICS		A1
TB8100 LOGIC DESIGN		
IPN: 220-02024-20	ISSUE: B	VARIANT NUMBER: ?
FILE DATE: Fri Jul 01 15:05:18 2005		
ENGINEER: SH	FILE NAME: 220_02024	SHEET NUMBER: 12 OF 18

REV/ISS	AMENDMENTS	DRAWN	CHKD	D.O.	APVD	DATE
1						

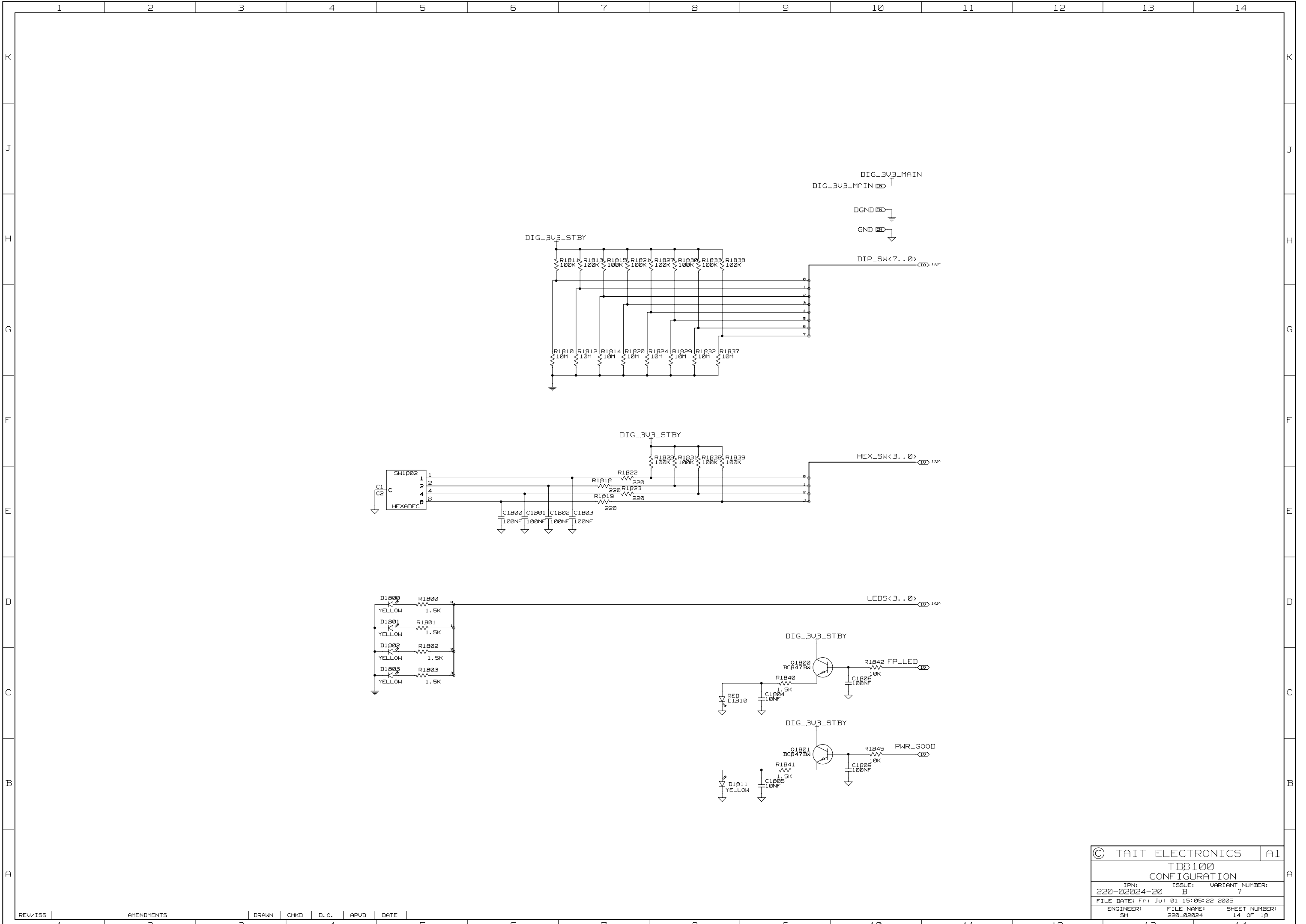

© TAIT ELECTRONICS		A1
TB8100 CONFIGURATION		
IPN: 220-02024-20	ISSUE: B	VARIANT NUMBER: ?
FILE DATE: Fri Jul 01 15:05:22 2005		
ENGINEER: SH	FILE NAME: 220_02024	SHEET NUMBER: 14 OF 18

REV/ISS	AMENDMENTS	DRAWN	CHKD	D.O.	APVD	DATE
1						

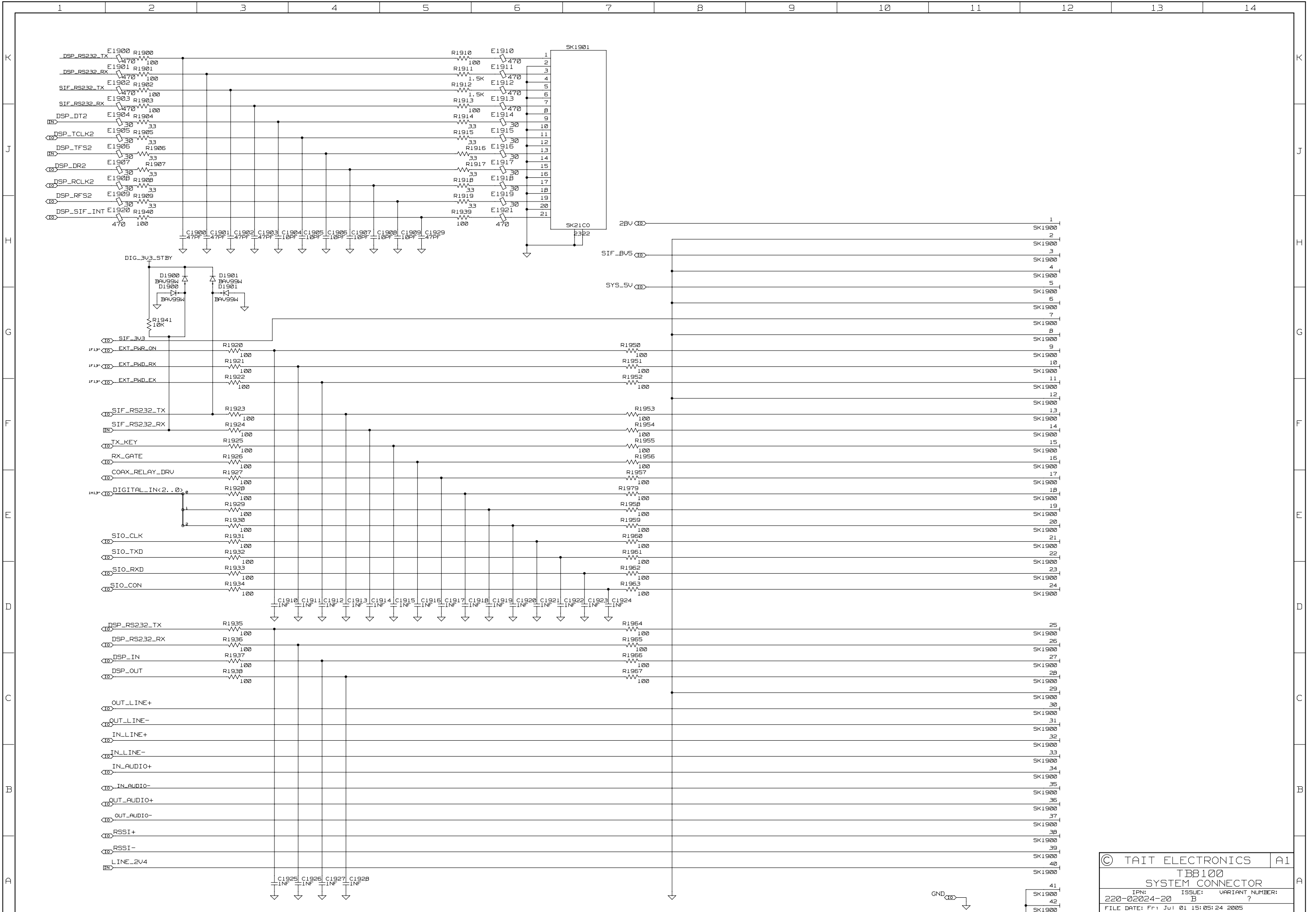

© TAIT ELECTRONICS		A1
TB8100 SYSTEM CONNECTOR		
IPN: 220-02024-20	ISSUE: B	VARIANT NUMBER: ?
FILE DATE: Fri Jul 01 15:05:24 2005		
ENGINEER: SH	FILE NAME: 220_02024	SHEET NUMBER: 15 OF 18

REV/ISS	AMENDMENTS	DRAWN	CHKD	D.O.	APVD	DATE
1						

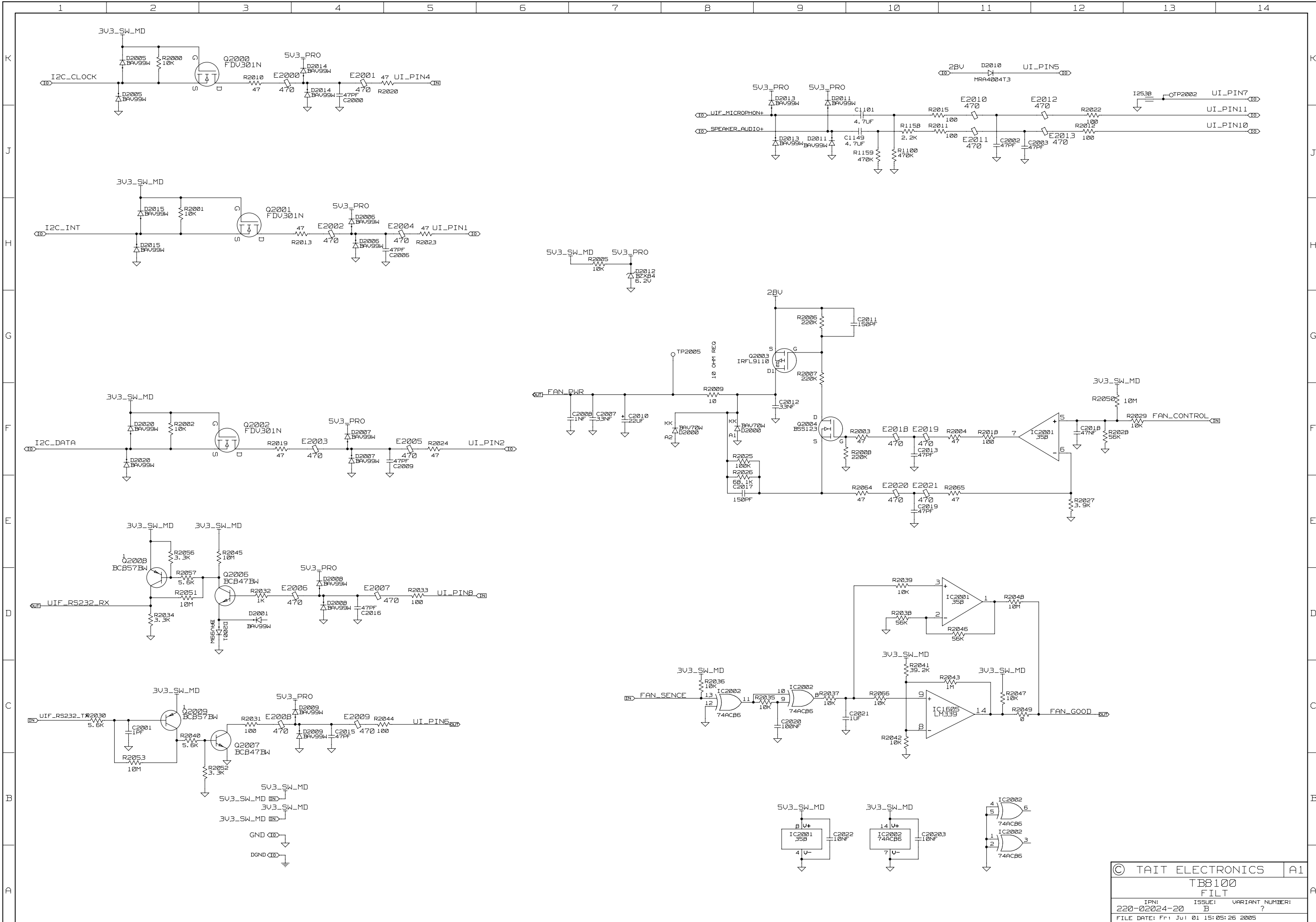

© TAIT ELECTRONICS		A1
TB8100		
FILT		
IPN:	ISSUE:	VARIANT NUMBER:
220-02024-20	B	?
FILE DATE: Fri Jul 01 15:05:26 2005		
ENGINEER:	FILE NAME:	SHEET NUMBER:
SH	220_02024	16 OF 18

REV/ISS	AMENDMENTS	DRAWN	CHKD	D.O.	APVD	DATE
1						



© TAIT ELECTRONICS		A1
TB8100 DIG_CONN		
IPN: 220-02024-20	ISSUE: B	VARIANT NUMBER: ?
FILE DATE: Fri Jul 01 15:05:28 2005		
ENGINEER: SH	FILE NAME: 220_02024	SHEET NUMBER: 17 OF 18

REV/ISS	AMENDMENTS	DRAWN	CHKD	D.O.	APVD	DATE
1						

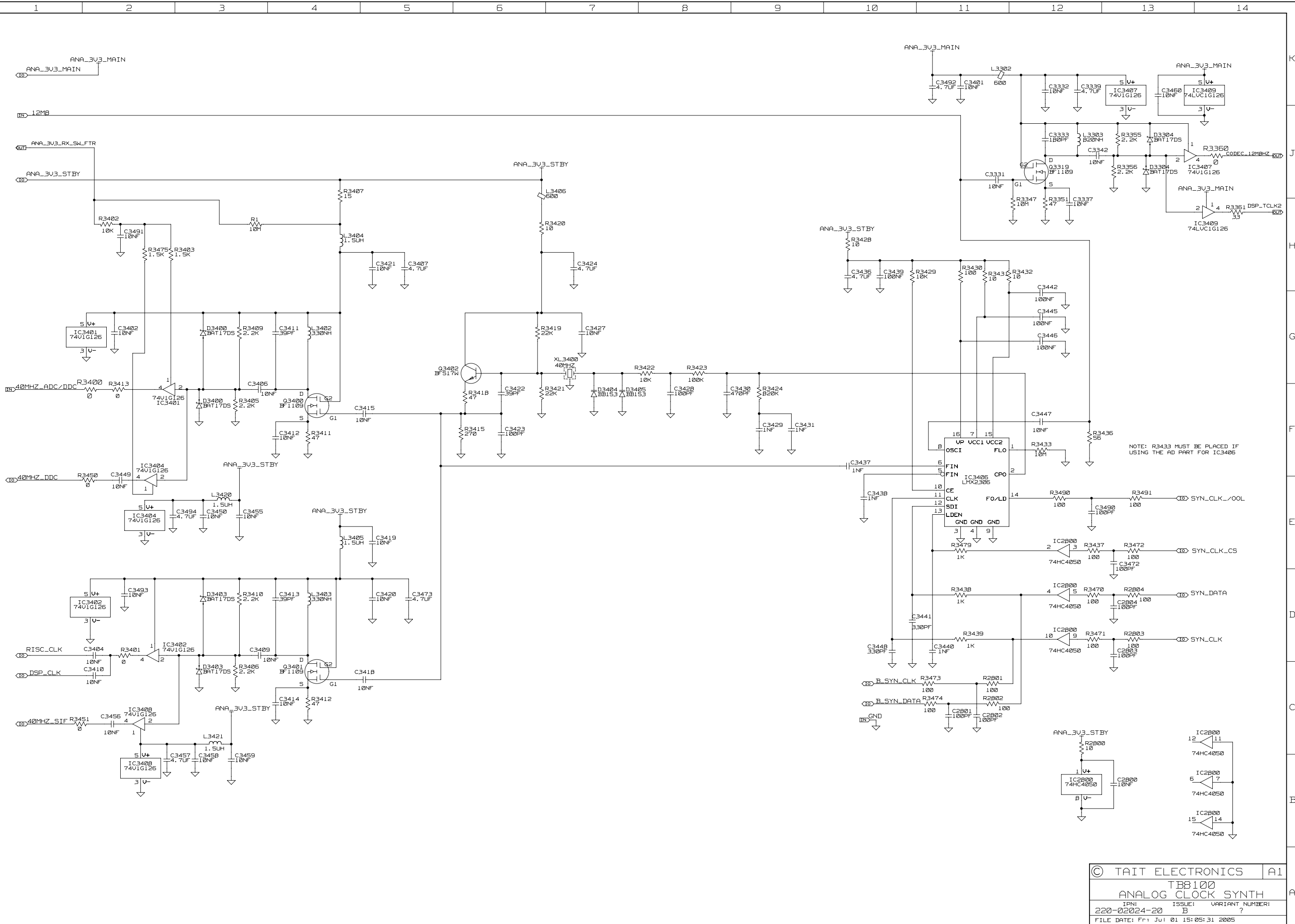

© TAIT ELECTRONICS		A1
TB8100		
ANALOG CLOCK SYNTH		
IPN: 220-02024-20	ISSUE: B	VARIANT NUMBER: ?
FILE DATE: Fri Jul 01 15:05:31 2005		
ENGINEER: SH	FILE NAME: 220_02024	SHEET NUMBER: 1B OF 1B

REV/ISS	AMENDMENTS	DRAWN	CHKD	D.O.	APVD	DATE
1				4		
3						